

R85A **SMART**

OPERATING WEIGHT: 8000 kgs

GROSS POWER : 76 HP @ 2200 rpm

BUCKET CAPACITY: 0.32 - 0.70m³



MOVING YOU **FURTHER**

R85A **SMART**

BEST-IN CLASS PERFORMANCE

- Advanced CAPO system
- Hydraulic flow summation
- Regeneration system
- Excellent digging forces



OPERATOR COMFORT

- Spacious cabin
- Fully adjustable seat
- Enhanced visibility
- User friendly functionality



IMPROVED FUEL EFFICIENCY

- Electro mechanical control system
- One touch deceleration
- Auto deceleration system
- Efficient breaker mode



DESIGNED FOR SMART WORK



Increased Machine Durability

- Strengthened undercarriage
- Proven upper structure
- Durable parts
- Reinforced front attachment



Simplified Maintenance

- Easy serviceability
- Extended maintenance
- Large capacity fluid tank
- Low life cycle cost



Parts & Support

- Hyundai genuine parts
- Max parts availability
- On-site product support
- Remote management system (Hi-Track)



Performance

PRIDE AT WORK

Hyundai construction equipment strives to build state-of-the-art earthmoving equipment to give every operator maximum performance, more precision, versatile machine preferences, and proven quality.

New technologies designed to improve performance and precision, make the Hyundai excavator smooth, fast and easy to control. Take pride in your work with Hyundai!



ENGINE

The 76 HP, Kirloskar 4R1040NA engine is built for power, reliability, efficiency to deliver high performance and low fuel consumption.



R85A **SMART**



ADVANCED HYDRAULIC SYSTEM

Hydraulic pressure sensing system provides wide range of flow at various workloads. Open center Main Control Valve (MCV) ensures faster response and maximum efficiency. Travel & swing motor provides excellent mobility and faster cycle time.

POWER MODE

Working Mode	Advantage
H Mode	<ul style="list-style-type: none">• Maximum Power• Fast Cycle time
S Mode	<ul style="list-style-type: none">• Balance between power and fuel efficiency
L Mode	<ul style="list-style-type: none">• Better fuel efficiency
Breaker Mode	<ul style="list-style-type: none">• Sets pump flow to optimal level and boosts efficiency

IMPROVED SWING TORQUE & DUAL TRAVEL SPEED

10% increase in swing torque & efficient travel system improves overall cycle time.



BEST IN CLASS DIGGING FORCES

Higher output even in tough working condition

- **Bucket - 5200 kgf**
- **Arm - 4000 kgf**



AUTO KICK DOWN FUNCTION & MAX TRACTION FORCE

Results in excellent maneuverability and climbing performance

- **Drawbar Pull - 5900 kgf**



Fuel Efficiency



IMPROVED FUEL EFFICIENCY

- Improved MCU with auto deceleration function
- Advanced hydraulics
- Increased return line diameter by 3/4 "



ONE TOUCH IDLE & AUTO DECELERATION

Prevents fuel losses by reducing engine rpm during no-load condition



EXCLUSIVE BREAKER MODE

Excellent fuel saving due to exclusive power for breaker operation



LARGE DIAMETER RETURN HOSES

Improve hydraulic performance for smooth loading operation & improved cycle time



Operator Comfort



360 degree allround visibility, fully open sunroof, added side lamp & mirror ensure comfortable, safe working environment.

OPERATOR SEAT

Easily adjustable Full suspension seat with adjustable arm rest

SMOOTH LEVER CONTROLS

Ergonomically placed lever controls reduces fatigue over long working hours.

SPACIOUS CABIN

More head room, large space, large door for easy entry and exit



MODERN INSTRUMENT PANEL

- Hydraulic oil temperature
- Fuel level
- Engine oil temperature
- 12 warning indicators
- Self diagnostic
- Maintenance management



TRAVEL PEDAL

- Rubber coated travel pedal
- Added Foot rest



CABIN FAN



SUNVISOR



10 STAGE RPM DIAL



SUNROOF



Reliability



DURABLE FRONT STRUCTURE

Use of specialized advance steel plates and reinforced design for higher strength and durability



RUGGED UNDERCARRIAGE

X frame provides excellent resistance to torsional bending to enhance structure life

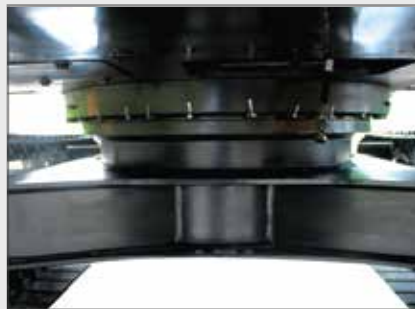

BALANCED SWING SYSTEM

Swing gear uses a ball bearing to absorb radial and thrust load



RELIABLE ELECTRICALS

- Dust and water proof connectors
- Longer component life



CASTED IDLER

Built to withstand high shock & impact load



BELLY GUARD

Additional protection from external damage



TRACK LINK

Thicker track link for longer life



Serviceability

EXTENDED MAINTENANCE INTERVAL

Enhanced filtration system extends hydraulic life upto 5000 hrs and Engine oil life upto 500 hrs, which reduces the maintenance cost

CHANGE INTERVAL

Hydraulic oil	5000 hrs
Hydraulic filter	1000 hrs
Engine oil	500 hrs
Engine Filter	500 hrs

MAINTENANCE MANAGEMENT



SELF DIAGNOSTIC SYSTEM



LARGE LCD MONITOR

Operator can check the machine's vital signs without any difficulties

- **Maintenance Management**
Proactive maintenance
- **Self Diagnostic**
Reduces down time
- **Warning Indicator**
Ensures safe working

EASY ACCESSIBILITY

Hyundai's SMART machines feature easy service access to increase machine uptime and reduce maintenance cost

FULLY OPENING ENGINE HOOD

Fully openable engine hood makes daily service checks easier even from the ground





Safety

SAFETY - MORE THAN A PEACE OF MIND AND OPERATOR CONFIDENCE

Cabin is integrally welded using high strength steel to provide enhanced protection. Handrails and steps are provided for easy operation. Anti-slip pads provide safety against skidding while climbing machine.

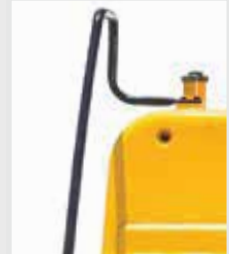

COUNTER BALANCE VALVE

Works as a hydrostatic brake and prevents machine against accidental roll down in steep gradients.



BOOM & ARM HOLDING SYSTEM

Prevent attachments from drifting against gravity due to prolonged overhanging.



ANTI RESTART FUNCTION

Prevents starter from damage during engine operation



BATTERY DISCONNECT SWITCH

Cut off power during maintenance and protect batteries from excessive drain



AUTO ENGINE OVERHEAT PREVENTION

Auto Deceleration with activation of engine overheat warning to avoid catastrophic failure



Parts & Support

HYUNDAI GENUINE PARTS

Developed in synergy with our machines, Hyundai parts and lubricants ensure that you get the high levels of performance, reliability and safety that come with the complete Hyundai experience.

Enjoy the confidence and assurance of the most stringent testing procedures and the high quality manufacturing processes safeguarding your machine's health. Experience the versatility of our 200+ strong outlet network across India

WHY RISK IT?

Maximize profits and extend your machine's life.



BENEFITS OF USING GENUINE HYUNDAI PARTS AND LUBRICANTS

- Genuine Hyundai Parts meet strict specifications and standards in Chemistry, Microstructure and Tensile Strength.
- Benefit from the continuous improvements and advancements made by Hyundai's technical team
- Improved performance of hydraulics and engine components
- Enjoy greater productivity with higher uptime
- Higher resale values
- Reduced oil consumption and unexpected breakdowns
- Enhanced component life



Our unique remote management system allows customers to access machine operating information & obtain service & maintenance alerts at the touch of a button



INCREASED PRODUCTIVITY

Remote management system empowers you to enhance the efficiency of your operations. Make better decision by comparing the machine's operating time with its travelling idling & breaker use duration.

CONVENIENT & EASY MONITORING

Enjoy round the clock and on the move access to your machine information through the website or mobile app.



PROACTIVE MAINTENANCE

Access your machines service & maintenance history with the utmost convenience. Plan your service schedules intelligently with our regular reminders.

SELECT REPORTS	
Geo Zone In/Out Detail	<input checked="" type="radio"/>
Fault Code	<input type="radio"/>
Vehicle Usage Summary	<input type="radio"/>
Temperature Record	<input type="radio"/>

ALARMS

Get notified of system alarms & protect your machine from critical faults & experience repairs.



SECURITY & FLEET MONITORING

Protect your machine from theft or unauthorized use. GPS features allows you to create a geo-fence & alerts you if the machine moves out of the defined boundary.



Specifications

Engine

Maker/Model		KIRLOSKAR 4R1040NA	
Rated flywheel horse power	SAE	J1995 (Gross)	76 HP (56.7 kW) @ 2200 rpm
		J1349 (Net)	73 HP (54.4 kW) @ 2200 rpm
		6271/1 (Gross)	77 PS (56.7 kW) @ 2200 rpm
		6271/1 (Net)	74 PS (54.4 kW) @ 2000 rpm
Max Torque		29.5 kgf.m (214 lbf.ft) @ 1320 rpm	

Hydraulic System

Main pump	
Type	Two variable displacement piston pumps
Max. flow	2 x 75.6 lpm
Sub-pump for pilot circuit	Gear pump
Cross-sensing & fuel saving pump system	

Hydraulic motors

Travel	Two speed axial piston motor with counter balance valve and pairing brake
Swing	Axial piston motor with automatic brake

Relief valve settings

Implement circuits	280 kgf/cm ²
Travel	280 kgf/cm ²
Swing Circuit	210 kgf/cm ²
Pilot Circuit	35 kgf/cm ²
Service valve	Installed

Coolant & Lubricant Capacity

REFILLING	LITRE
Fuel tank	135
Engine coolant	10.8
Engine oil	11.5
Swing device-gear oil	1.5
Final drive (each)	1.2
Hydraulic system / Hydraulic tank	130 / 75

Drives & Brakes

Drive method	Fully hydrostatic type
Drive motor	Axial piston motor in-shoe design
Reduction system	Planetary reduction gear
Max. drawbar pull	5900 kgf (13,000 lbf)
Max. travel speed (high/low)	4.8 kmph (3 mph) / 3.0 kmph (1.9 mph)
Gradeability	35 Degree (70%)
Parking brake	Multi wet disc

Undercarriage

The X-leg type center frame is integrally welded with reinforced box-section track frames. The undercarriage includes lubricated rollers, idlers, track adjusters with shock absorbing spring and sprockets and track chain with triple grouser shoes.

Centre frame	X-leg type
Track frame	Pentagonal box type
No. of shoes on each side	38
No. of carrier rollers each side	1
No. of track rollers. each side	5
No. of rail guard each side	1

Swing System

Swing motor	Axial piston motor
Swing reduction	Planetary gear reduction
Swing bearing lubrication	Grease bathed
Swing brake	Multi wet disc
Swing speed	12.0 rpm

Operating Weight

Shoe Width mm (in)	Operating weight kg (lb)	Ground pressure kgf/cm ² (psi)
450 mm (18")	8,000 (17,637)	0.26 (3.70)

Dimensions

mm

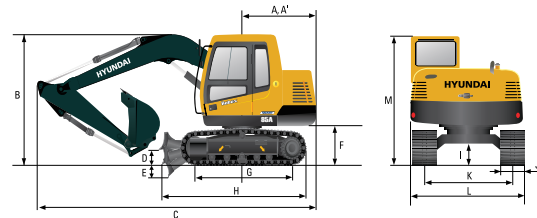

A	Tail swing radius	1750
A'	Rear-end length	1727
B	Overall height of boom	2750
C	Overall length	6080
D	Ground clearance of blade up	400
E	Depth of blade down	280
F	Ground clearance of counterweight	760
G	Tumbler distance	2130
H	Length of lower blade with dozer blade	3340
I	Min. ground clearance	360
J	Track shoe width	450
K	Track gauge	1750
L	Overall width of upperstructure	2260
M	Overall height of cabin	2640

Working Ranges mm

Boom length (std.)	3,700
Arm length (std.)	1,670

A	Maximum Digging Reach	6,330
A'	Digging Reach on Ground	6,190
B	Max Digging Depth	4,150
B'	Max- Digging Depth (8' level)	3,810
C	Vertical Digging Depth	3,200
D	Maximum Digging Height	7,260
E	Maximum Dumping Height	5,170
F	Minimum Swing Radius	1,750

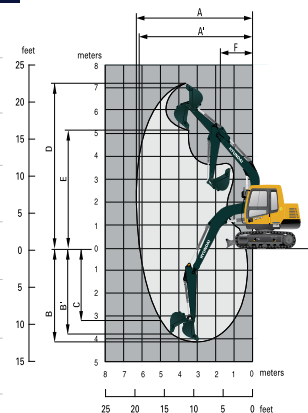



Lifting Capacities

LIFTING CAPACITIES R85A SMART



Rating over-front



Rating over-side

- Boom: 3.7m (12'2") • Arm: 1.67m (5'6") • Bucket: 0.35m³ (0.42 yd³) SAE Heaped
- Shoe: 450mm (18") triple grouser, dozer blade down with 400kg (890lb) Counterweight

Load point height m (ft)	Load radius						At max. reach			
	1.5 m (5.0 ft)		3 m (10.0 ft)		4.5 m (15.0 ft)		Capacity		Reach	
									m (ft)	
4.5m (15.0ft)	kg			*1800	*1800			*1680	1090	5.06
	lb			*3970	*3970			*3700	2400	(16.6)
3.0m (10.0ft)	kg	*3890	*3890	*2370	*2370	*1930	1300	*1710	820	5.75
	lb	*8580	*8580	*5220	*5220	*4250	2870	*3770	1810	(18.9)
1.5m (5.0ft)	kg			*3330	2350	*2230	1210	*1760	740	5.95
	lb			*7340	5180	*4920	2670	*3880	1630	(19.5)
Ground	kg			*3820	2160	*2430	1140	*1810	770	5.70
Line	lb			*8420	4760	*5360	2510	*3990	1700	(18.7)
-1.5m (-5.0ft)	kg	*4810	*4810	*3580	2130	*2230	1120	*1790	990	4.93
	lb	*10600	*10600	*7890	4700	*4320	2470	*3950	2180	(16.2)
-3.0m (-10.0ft)	kg	*4000	*4000	*2360	2220					
	lb	*8820	*8820	*5200	4980					

1. Lifting capacity is based on SAE J1097, ISO 10567.
2. Lifting capacity of the Robex Series does not exceed 75% of the tipping load with the machine on firm, level ground or 87% of full hydraulic capacity.
3. The load point is a hook (standard equipment) located on the back of the bucket.
4. (*) indicates the load limited by hydraulic capacity.





Specifications

BUCKETS

All buckets are welded with high-strength steel.

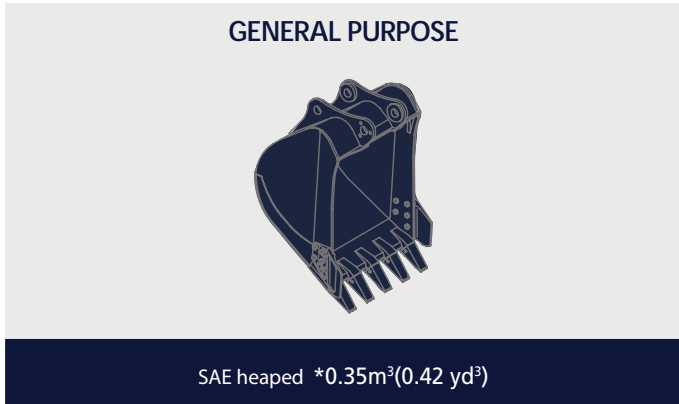

Capacity m ³ (yd ³)		Width mm (in)		Weight. kg (lb)	Recommendation mm (ft -in)
SAE heaped	CECE heaped	Without side cutters	With side cutters		3.70m (12' 2") Boom
* 0.32m ³ (0.42yd ³)GP	0.27m ³ (0.35yd ³)	754 (30")	900 (35")	317 (699)	■
◎ 0.32m ³ (0.38yd ³)HD	0.27m ³ (0.35yd ³)	720 (28.3")	815 (32.1")	313 (690)	■
* 0.35m ³ (0.42yd ³)GP	0.29m ³ (0.38yd ³)	754 (30")	900 (35")	330 (728)	▲

* : Standard backhoe bucket

◎ : Heavy Duty bucket

■ Applicable for materials with density of 1,600 kg/m³ (2,700lb/yd³) or less

▲ Applicable for materials with density of 1,100 kg/m³ (1,850 lb/yd³) or less

ATTACHMENT

Boom and arm are of all-welded with a low-stress, full-box section design. 3.70m (12'2") mono boom and 1.67m (5'6") Arm is available. Buckets are all-welded, high-strength steel implements.

Arm	Length Weight	mm (ft.in) kg (lb)	*1,670 (5' 6") 310 (680)
Bucket digging force	SAE	kN	44.1
		kgf	4,500
		lbf	9,920
	ISO	kN	51.0
		kgf	5,200
		lbf	11,460
Arm crowd force	SAE	kN	38.2
		kgf	3900
		lbf	8600
	ISO	kN	39.2
		kgf	4000
		lbf	8820

*: Standard arm weight including cylinder and linkage



Standard / Optional List

Standard Equipment

ISO standard cabin

All-weather steel cab with all-around visibility
Safety glass windows
Sliding fold-in front window
Sliding side window
Lockable door
Accessory box & Ashtray
Door and Cab locks, One key
Operators seat
Slidable joystick, pilot operated
Self diagnostic system
Centralized monitoring
Fuel level gauge
Engine coolant temperature gauge
Hydraulic oil temperature gauge
Sun visor for cabin inside

Warning

Engine coolant & fuel level
Engine oil pressure
Engine coolant temperature
Hyd. oil temperature
Low battery
Air cleaner clogging

Fan
Radio/USB Player
Two front working lights
Electric horn
Batteries (2x12v x 68AH)
Battery master switch
Removable clean out screen for oil cooler
Automatic swing brake
Removable reservoir tank
Water separator, fuel line
Boom holding system
Arm holding system

Counterweight (400kg, 882lb)
Mono boom (3.7m, 12'2")
Arm (1.67m, 5' 6")
Standard bucket (0.35m³, 0.42yd³)
Track shoes (450m, 18")
Track rail guard
Lower frame under cover
Operator kit
Tool kit
Remote management system (Hi-Track)

Optional Equipment

Beacon lamp
Single acting piping kit
Travel alarm
Operator seat belt
Fire extinguisher
Track shoes (600mm, 24")
HD bucket (0.32m³, 0.38yd³)
General purpose bucket (0.32m³, 0.42yd³)
Salt bucket (0.70m³, 0.84yd³)

